

 **Installationsanvisning**

Centerlift 980/981

 **Installasjonsveiledning**

Centerlift 980/981

 **Installation Instructions**

Centerlift 980/981

 **Montageanleitung**

Centerlift 980/981

 **Instructions d'installation**

Centerlift 980/981

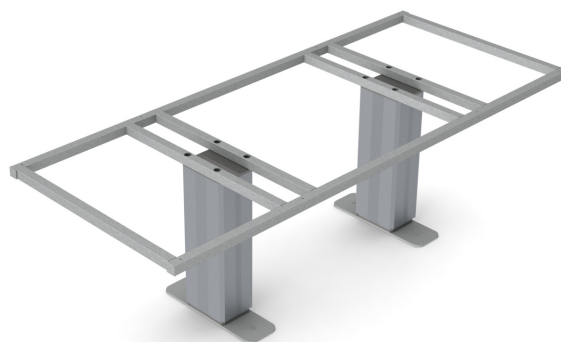
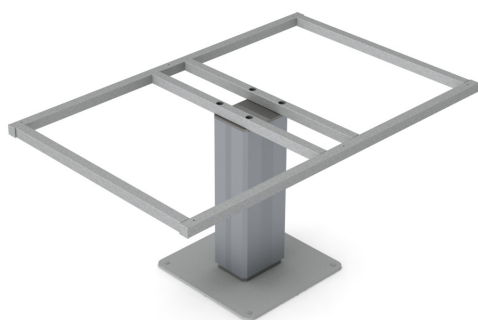





Granberg Interior AB
Box 6112
SE-600 06 Norrköping
Sweden

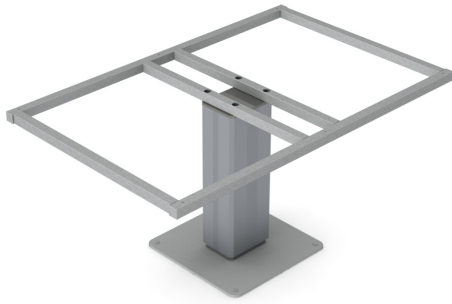



Support:
Tel. +46 (0) 11-19 77 57



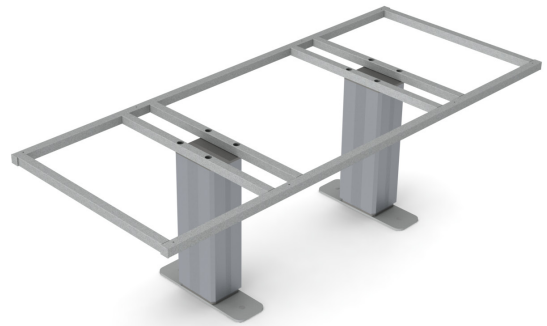

980/981 - Singel	
	230 V / 120 V 345 W / 324 W
	980 = 16 mm / s 981 = 28 mm / s
	980 = 300 mm 981 = 400 mm
	150 kg
	6 / 1h



980/981 - Double	
	230 V / 120 V 345 W / 324 W
	980 = 16 mm / s 981 = 28 mm / s
	980 = 300 mm 981 = 400 mm
	250 kg
	6 / 1h

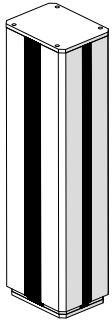

1x / 2x

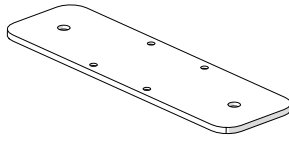

1x / 2x

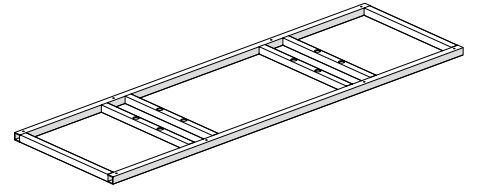

1x

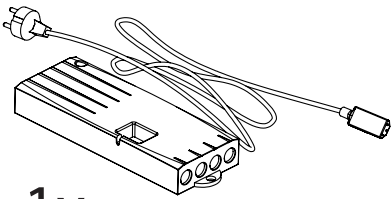

1x

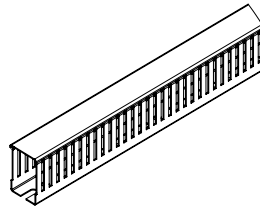

1x



4x

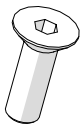

M8x25mm

4x / 8x

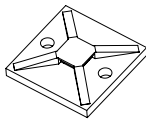

4x

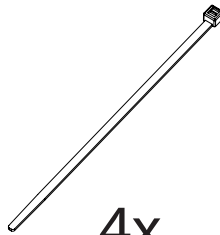

4x

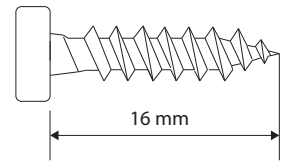

4x

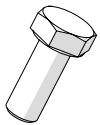

M8x20mm

4x / 8x



BR 8.8

4x / 8x

Accessory 61460+61461

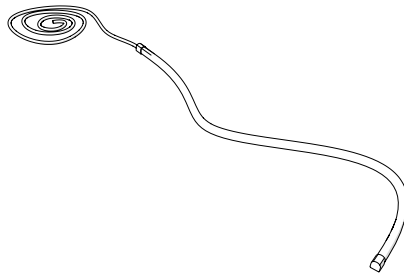

Accessory 390-00

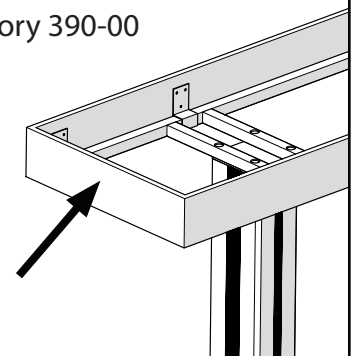

Accessory 61510

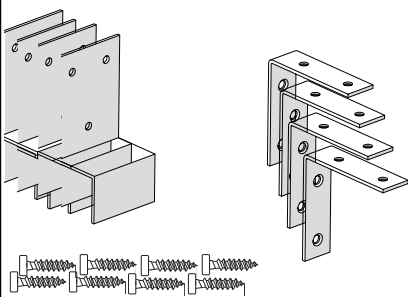

Accessory 61320

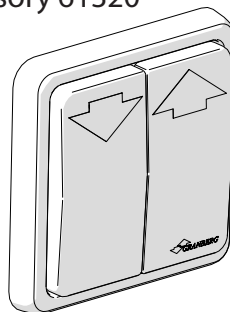

Accessory 61300

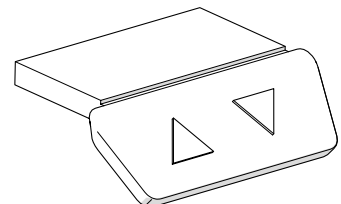

980 - Singel

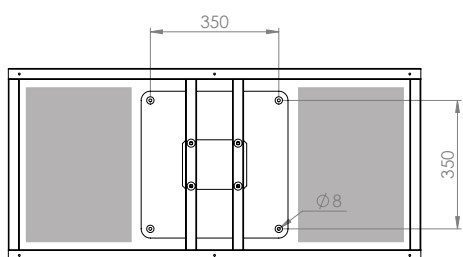
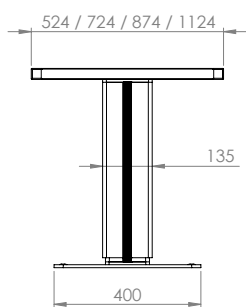
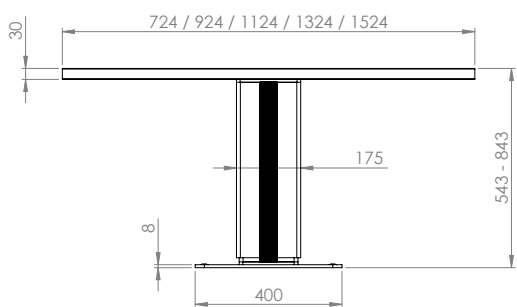

With brackets for wooden frame (Accessory)

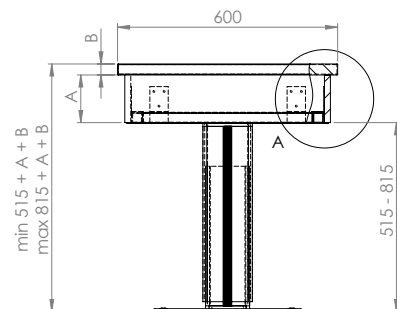

DETAIL A
SCALE 1 : 2

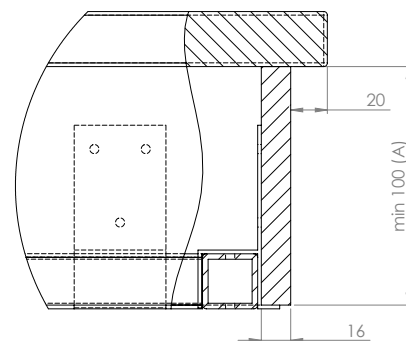

981 - Singel

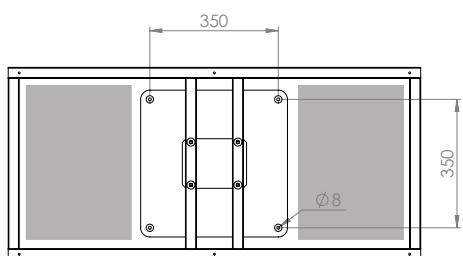
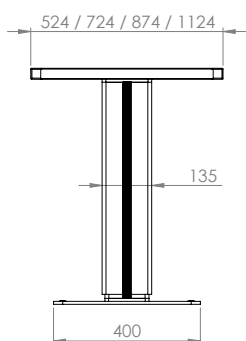
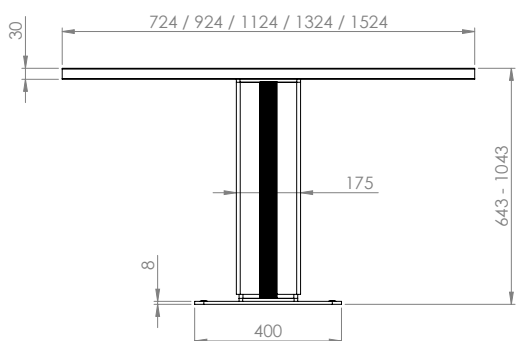

With brackets for wooden frame (Accessory)

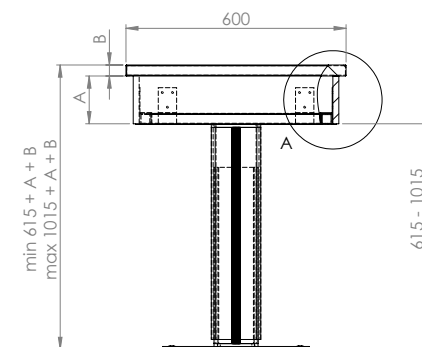

DETAIL A
SCALE 1 : 2

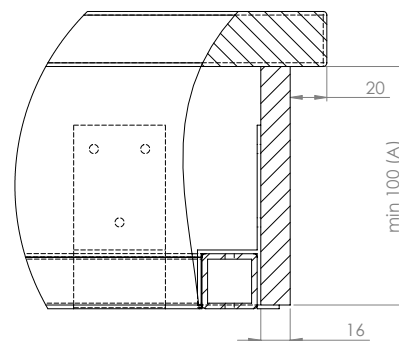

- SE** Fritt utrymme för installation av vatten och el
- NO** Fritt konsentrert område for installasjon av vann og elektrisitet
- EN** Freely concentrated area for the installation of water and electricity
- DE** Frei Region, die die Installation von Wasser und Strom
- FR** Zone librement concentré pour l'installation de l'eau et de l'électricité

980 - Double

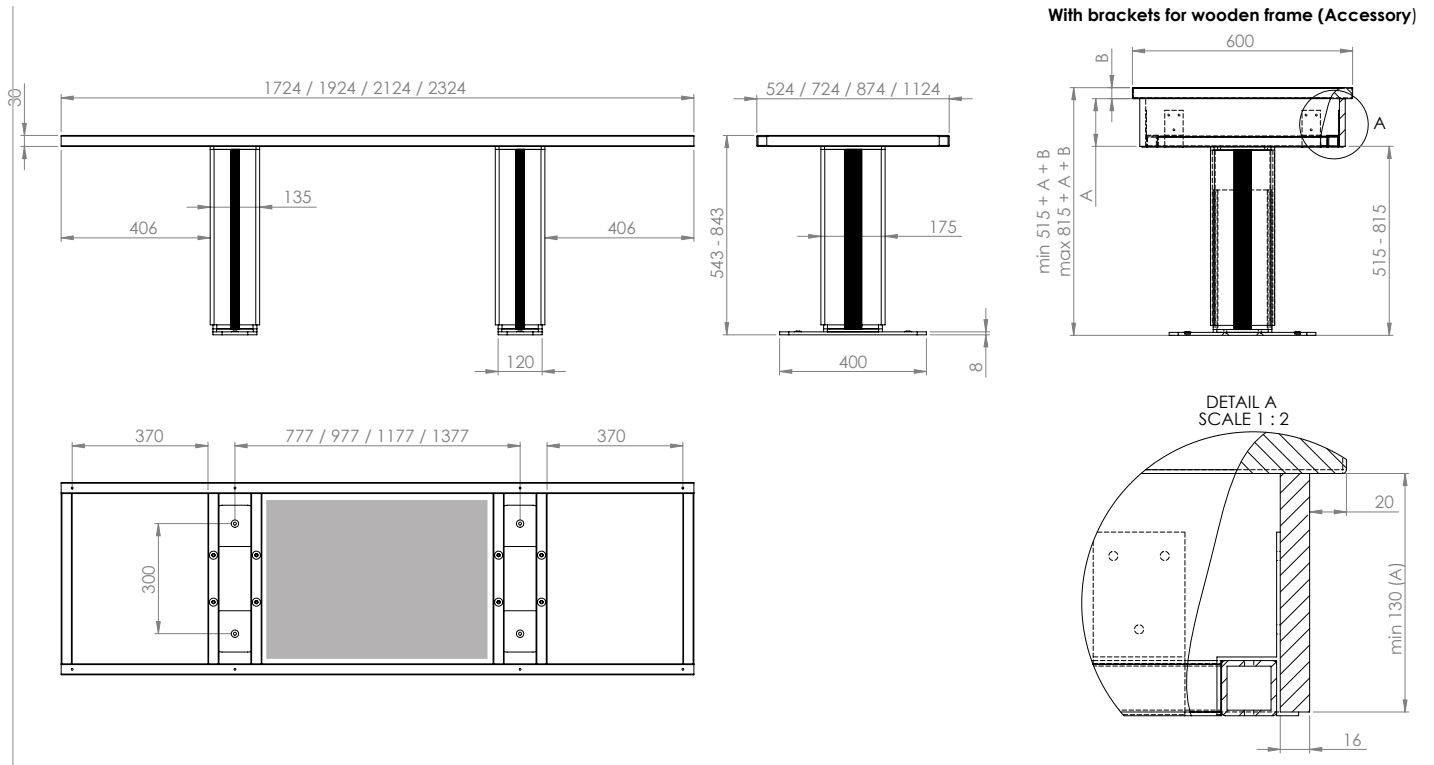

981 - Double

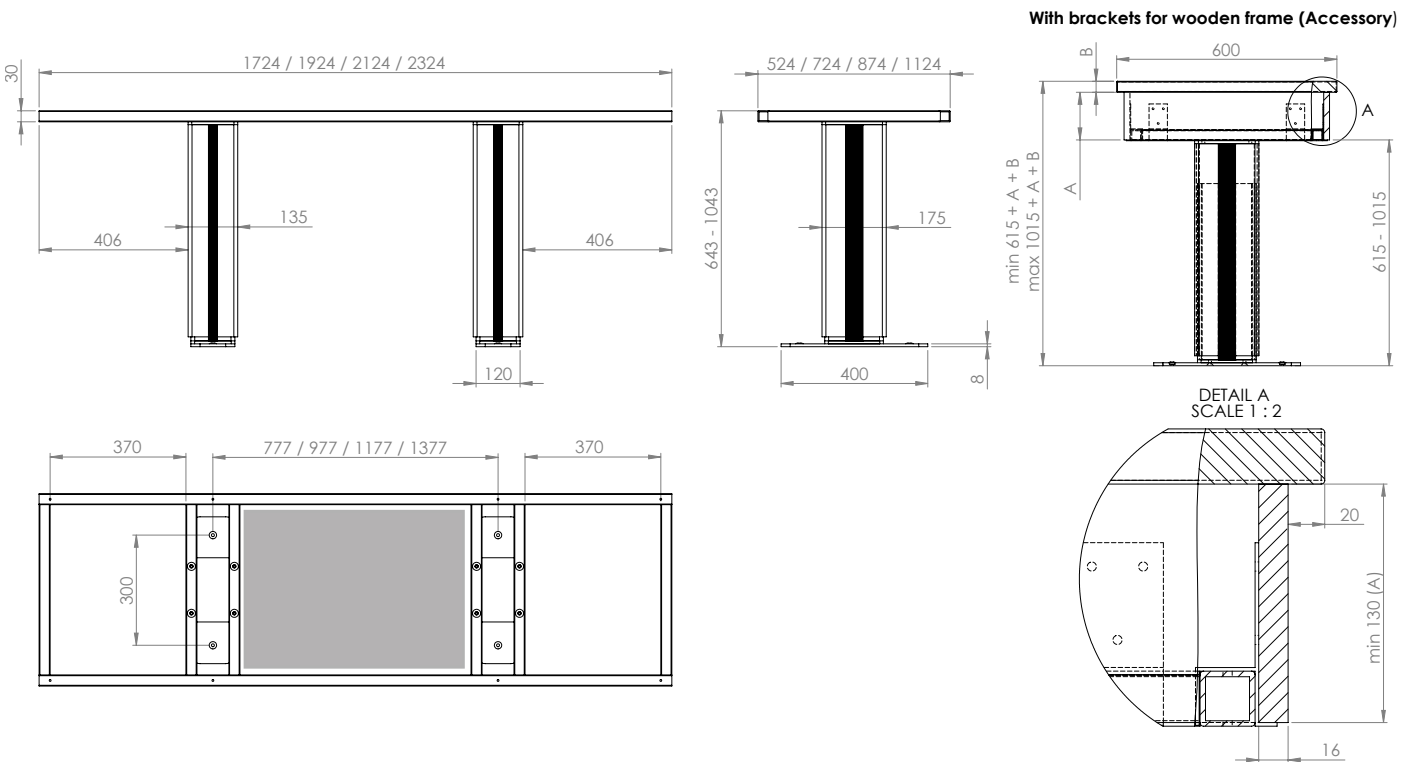

||

- SE** Fritt utrymme för installation av vatten och el
- NO** Fritt konsentrert område for installasjon av vann og elektrisitet
- EN** Freely concentrated area for the installation of water and electricity
- DE** Frei Region, die die Installation von Wasser und Strom
- FR** Zone librement concentré pour l'installation de l'eau et de l'électricité

1

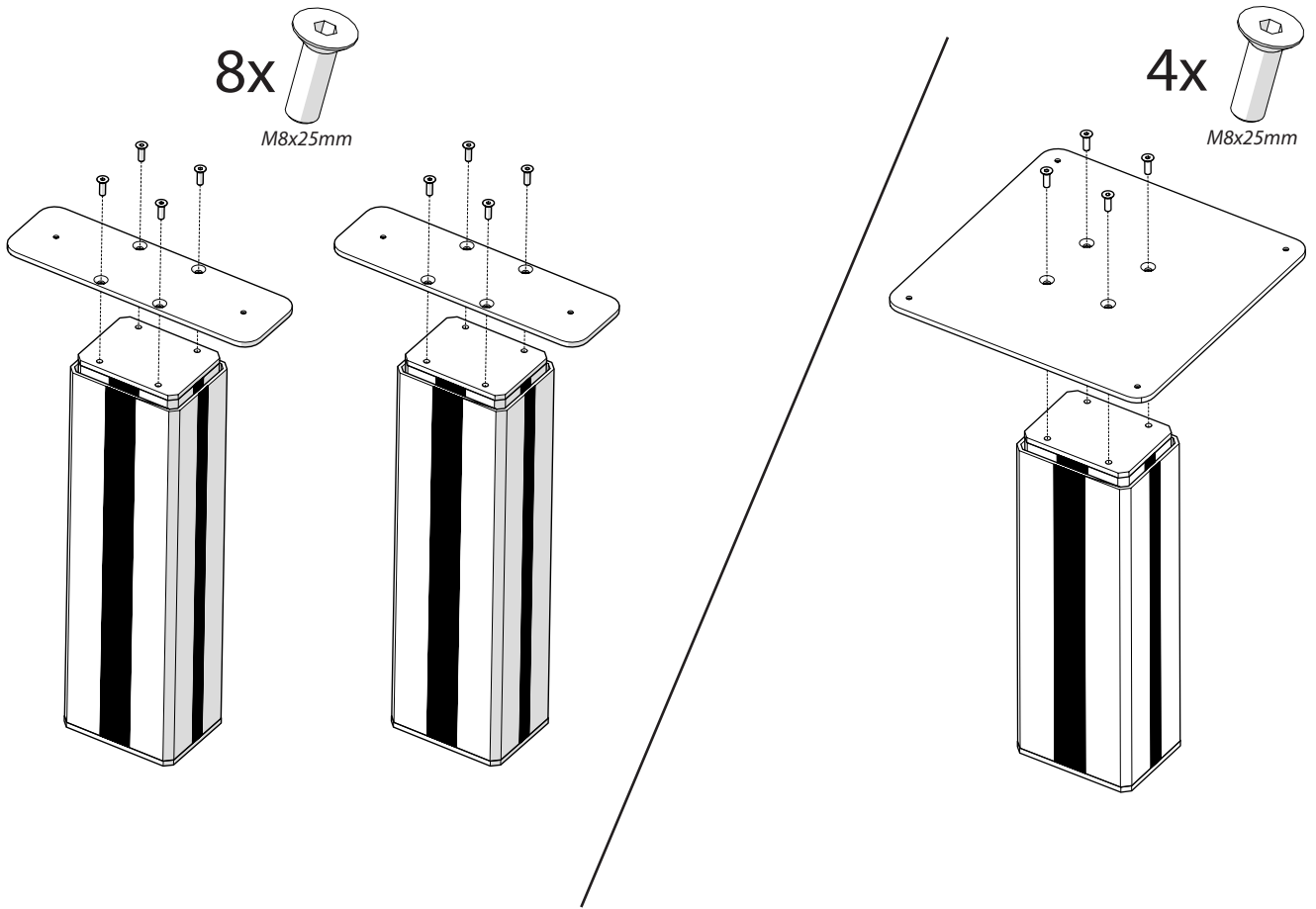

2

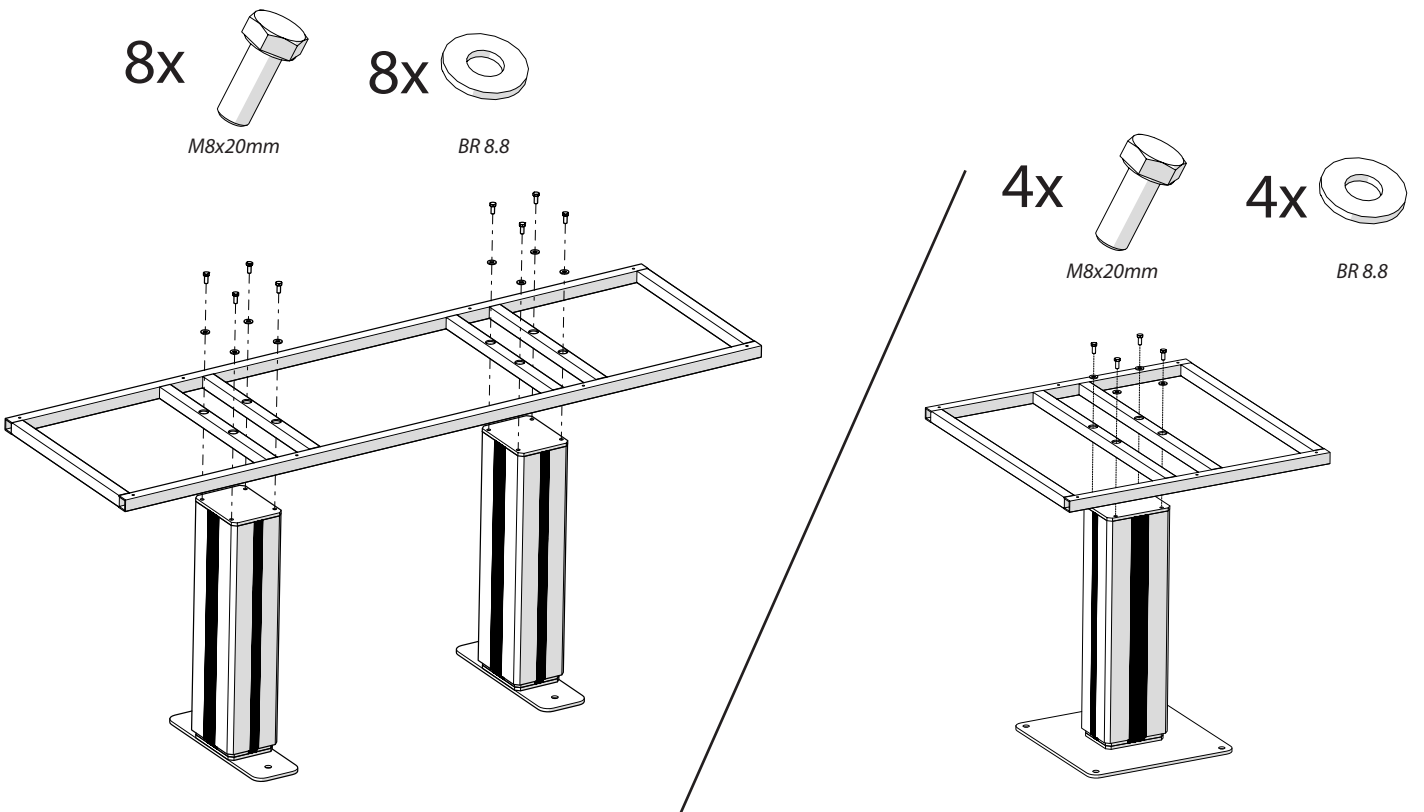

3

4x / 8x

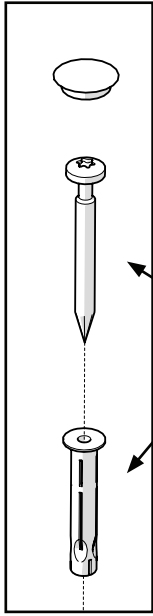

SE Medföljer ej
NO Ikke levert
EN Not supplied
DE Nicht im Lieferumfang
FR Non fourni

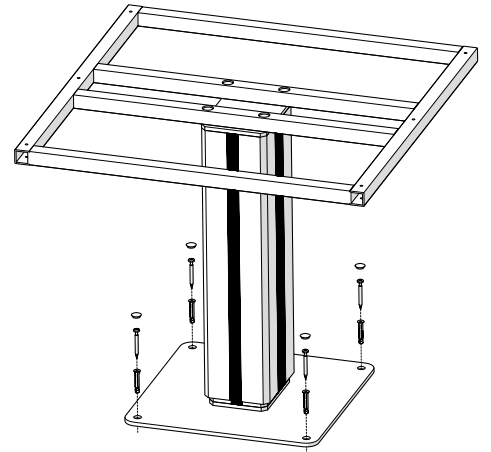
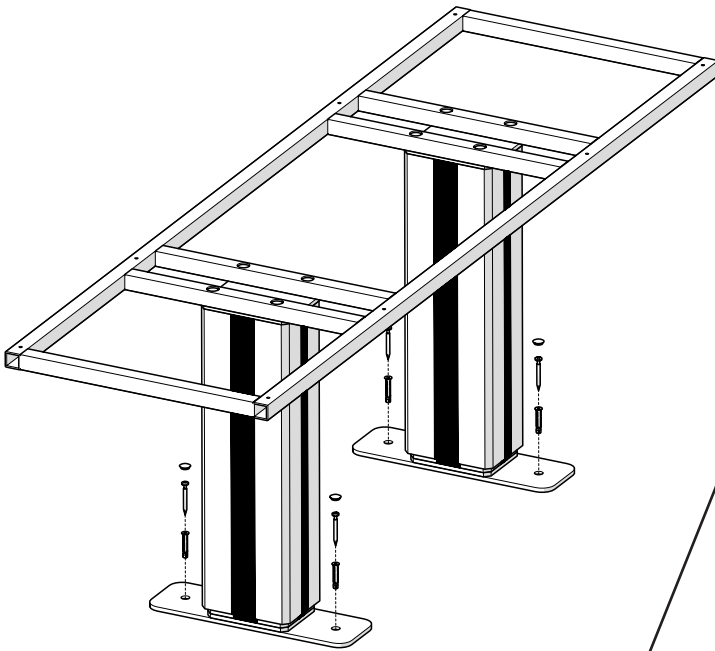
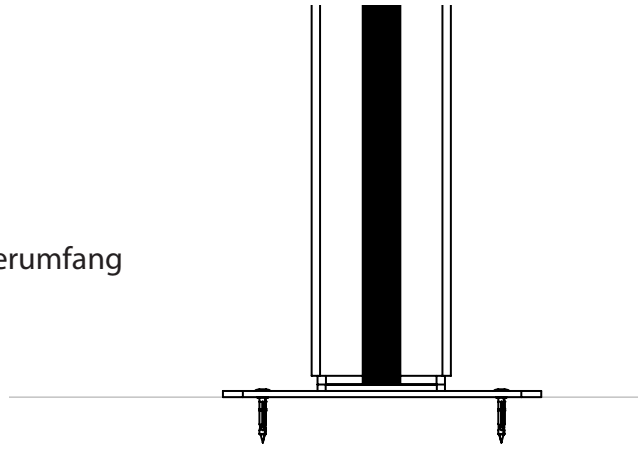

- (4.1)** SE Sarg fäste (Tillbehör 61510)
NO Sarg brakett (Tilbehør 61510)
EN Front fittings (Accessory 61510)
DE Felgenmontage (Zubehör 61510)
FR Mount jante (Accessoires 61510)

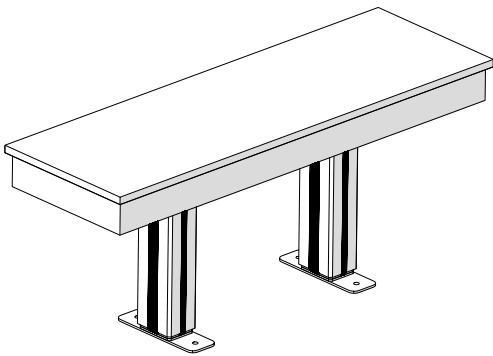
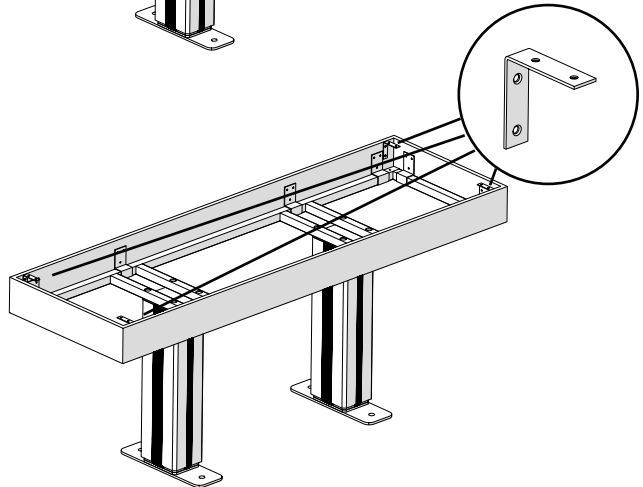
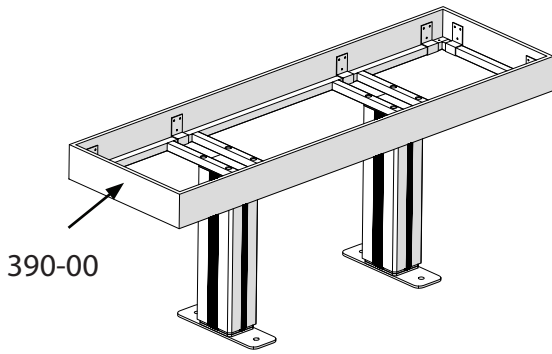
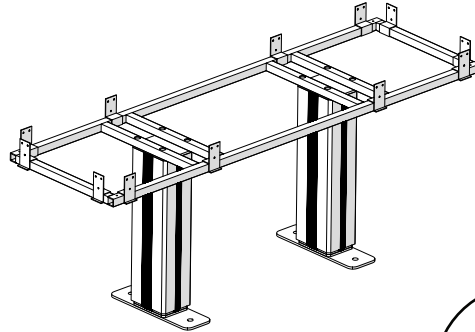
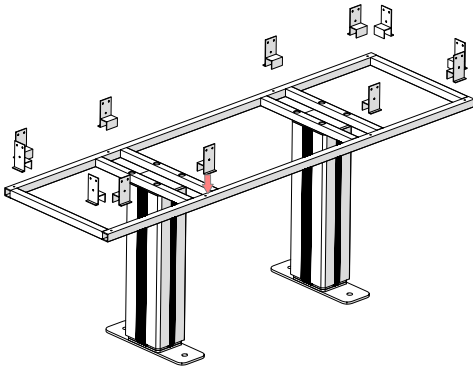
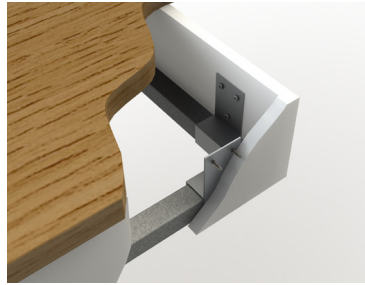

Y = MAX 20mm

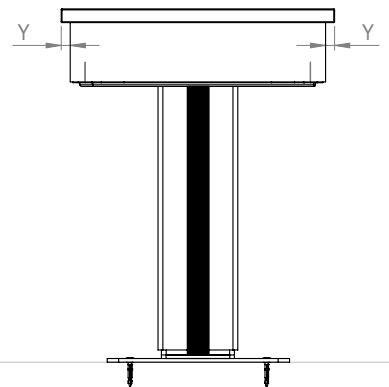
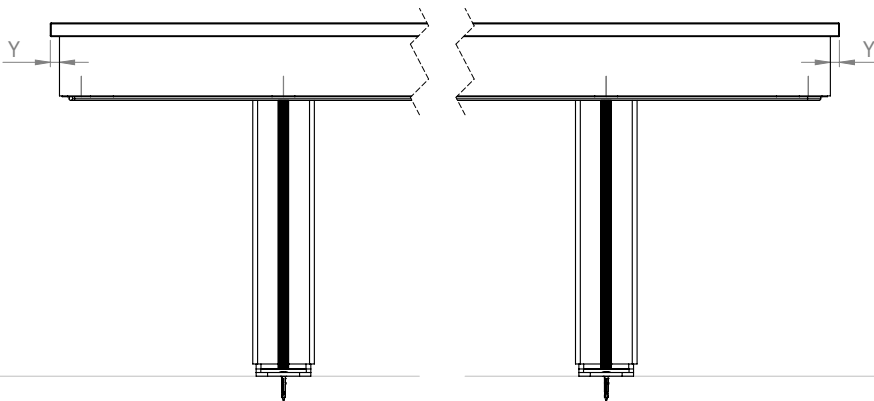

4.2

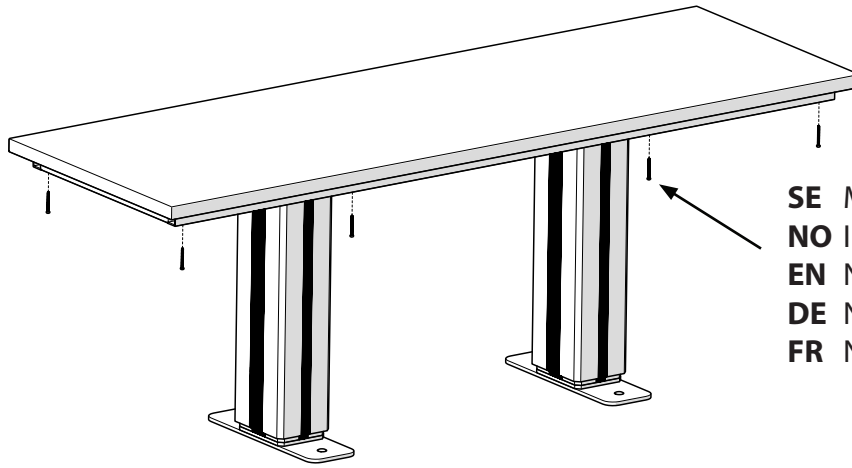

- SE Medfølger ej
- NO Ikke levert
- EN Not supplied
- DE Nicht im Lieferumfang
- FR Non fourni



$X = \text{MAX } 38\text{mm}$

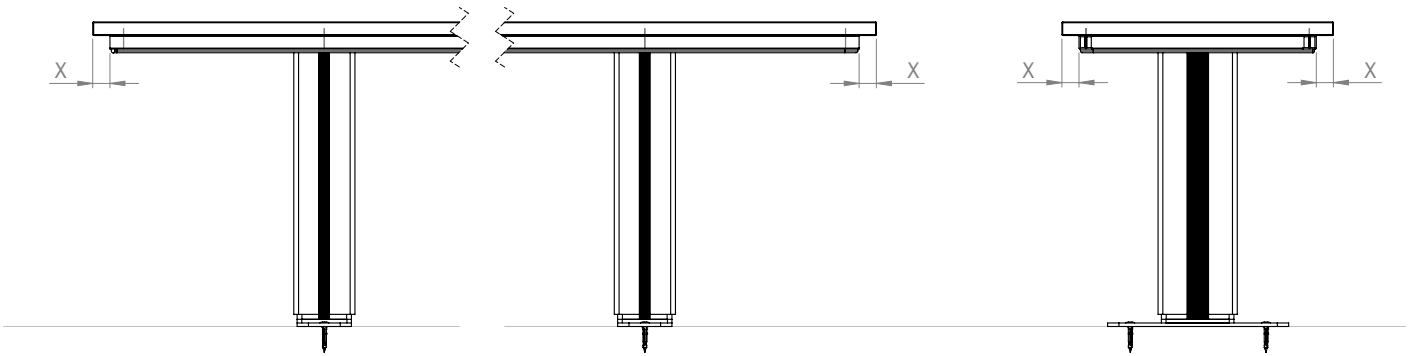

- (5)** SE Tillbehör 61460+61461
NO Tilbehør 61460+61461
EN Accessory 61460+61461
DE Zubehör 61460+61461
FR Accessoires 61460+61461

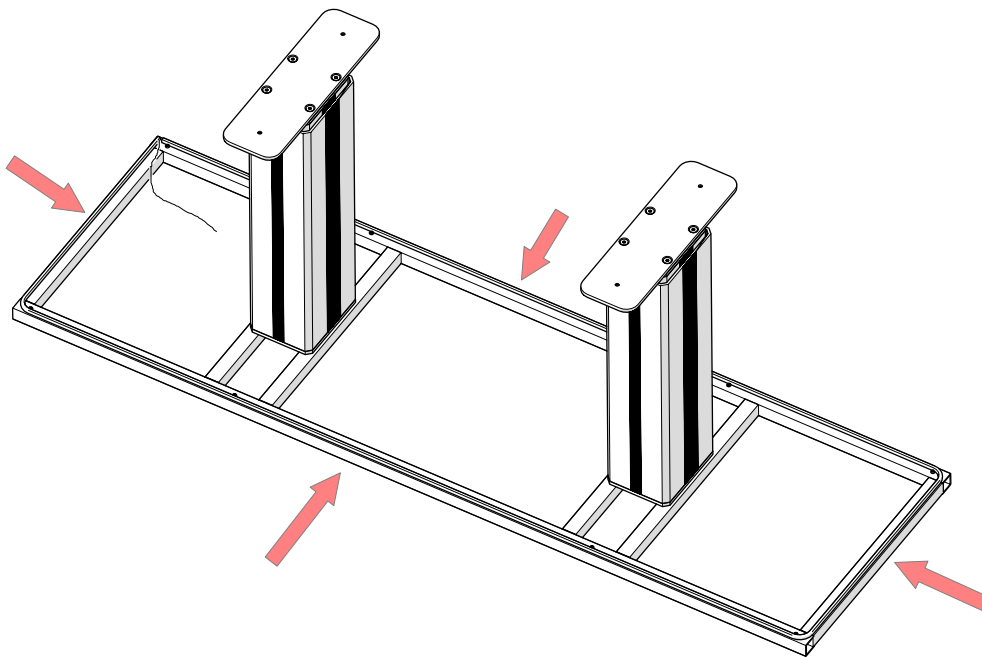
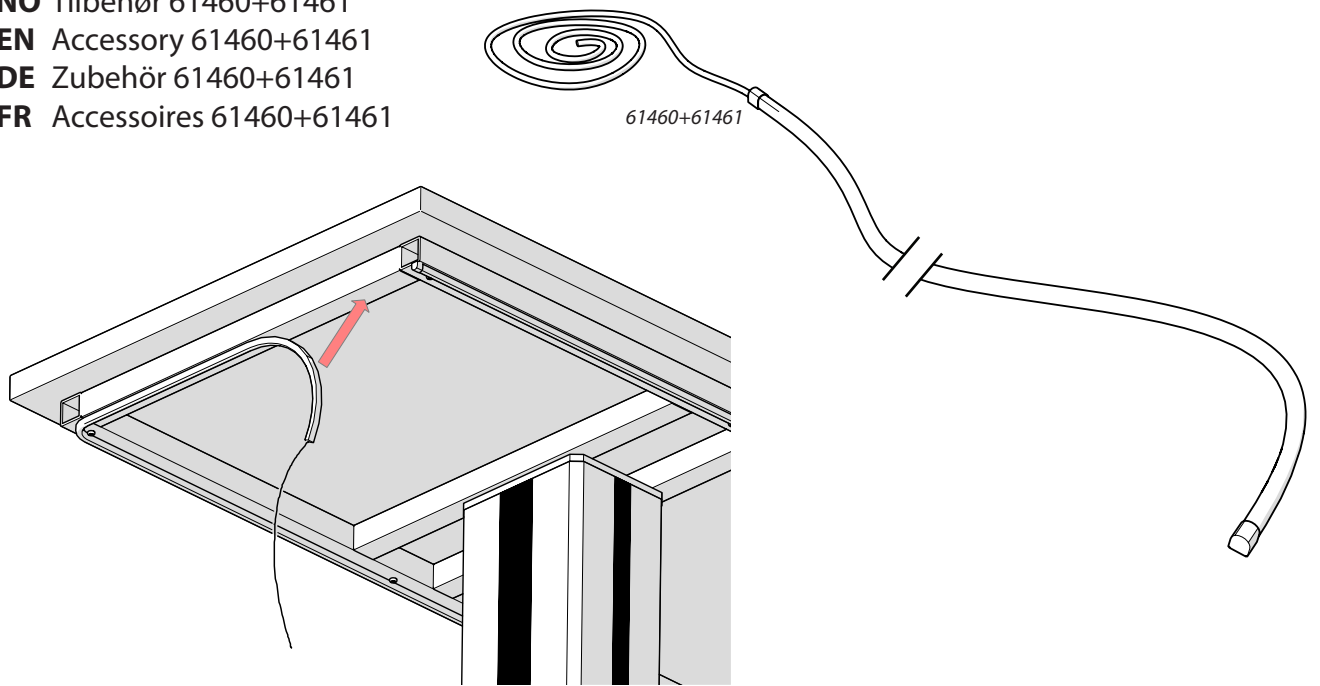

6

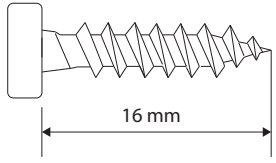

4x

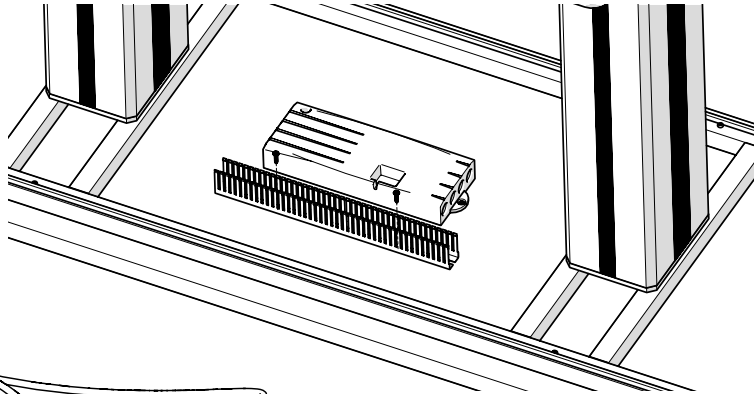
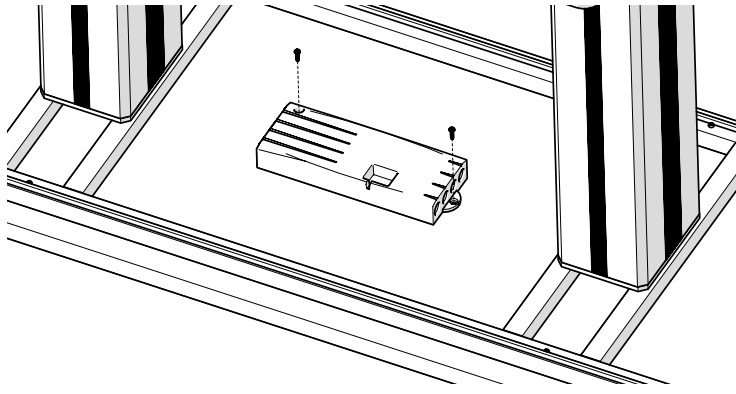

230V max 2,5A

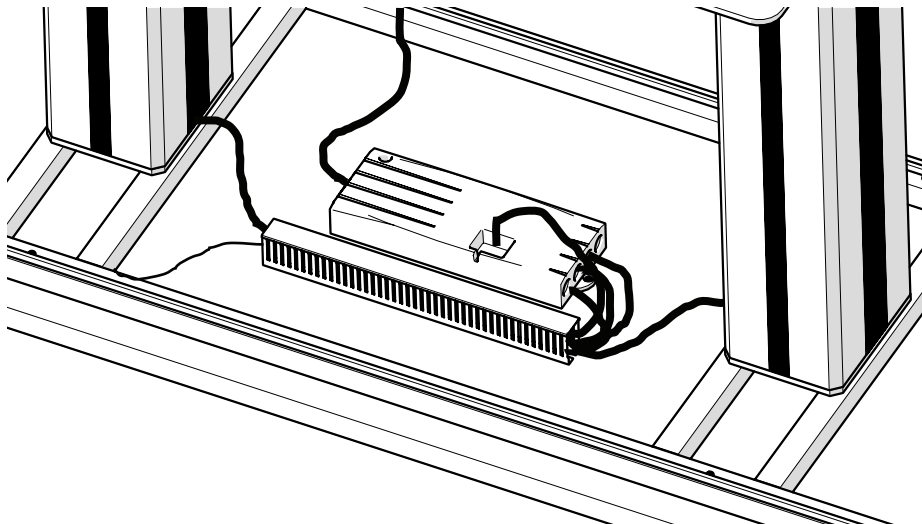
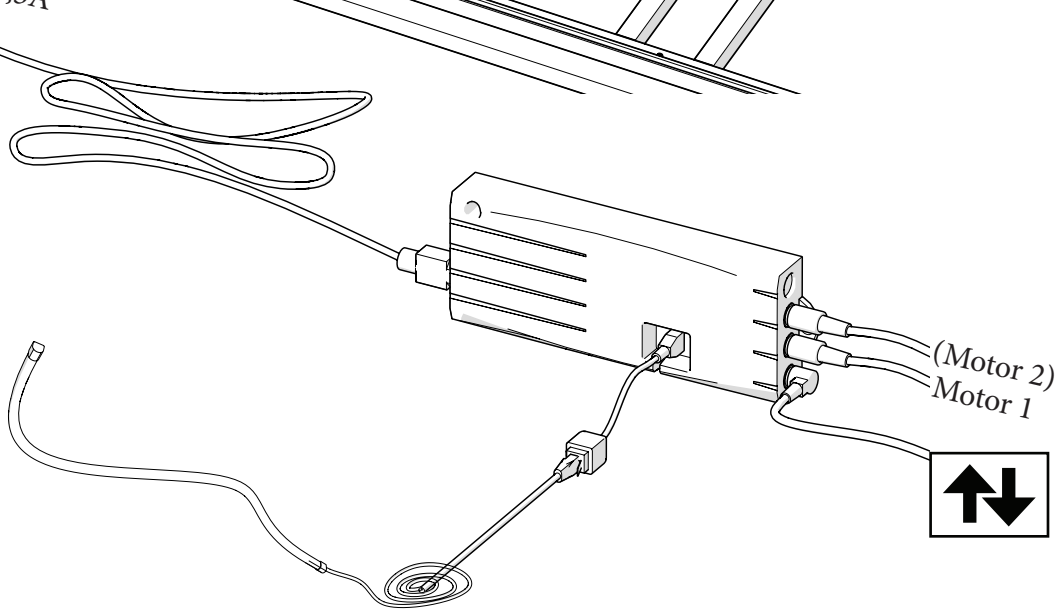

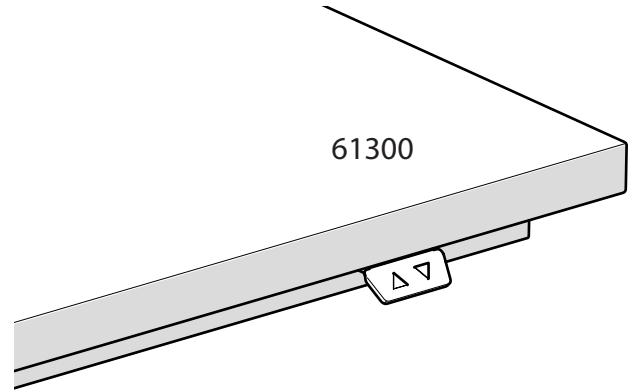
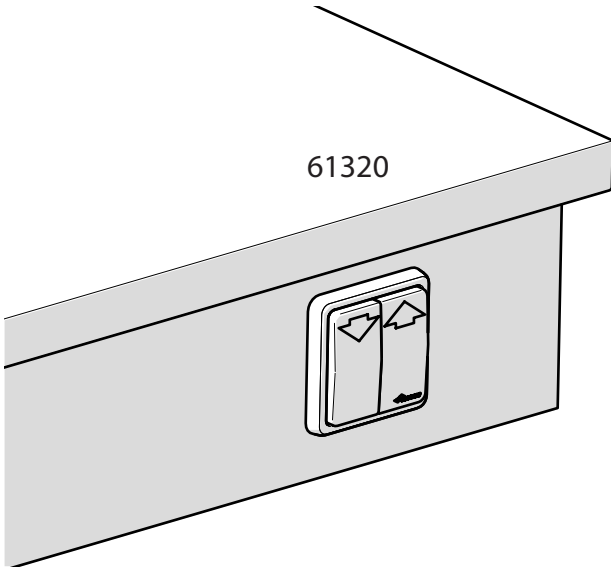

8

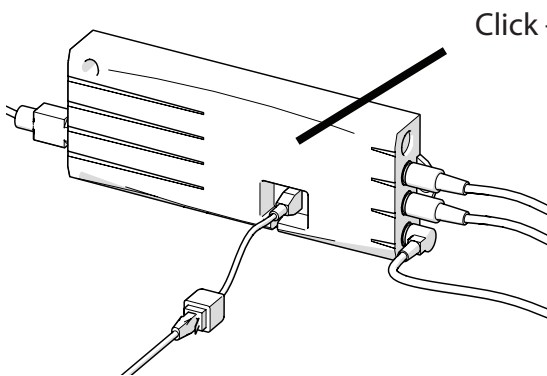
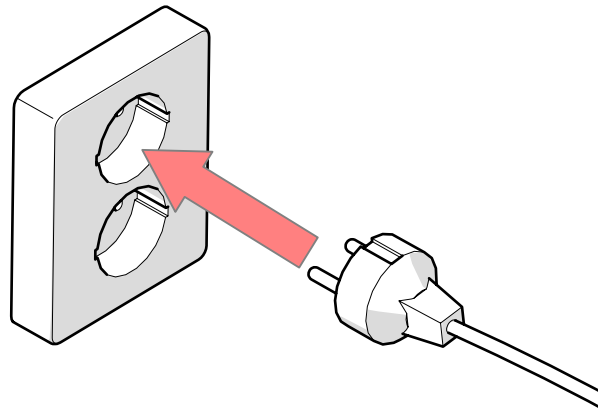

Click - Click - 3sec - Click - Click - Click

9

5 sec - Click - Click - Click = OK!

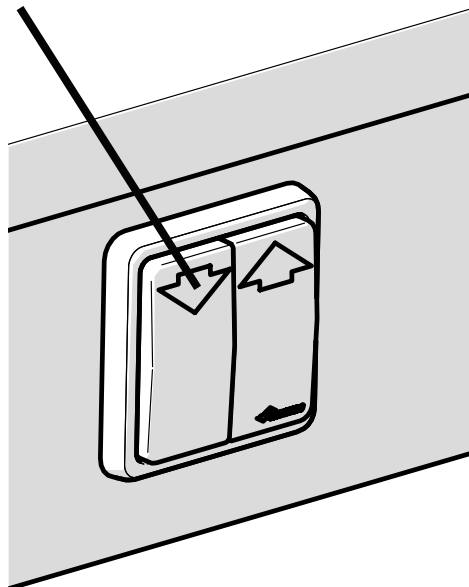

SE Funktionsprov

Efter installation ska komplett funktionsprov med full last genomföras:

Provkör lyftaren upp och ner hela vägen till respektive ändläge. Kontrollera att den går fritt utan hinder och missljud. Kontrollera att inga kablar och slangar kommer i kläm och att vatten- och avloppsslangar är fixerade i golv.

OBS!

Kör upp lyftaren till ändläge och kontrollera att slangarna är tillräckligt långa ovanför fixeringspunkten.

NO Funksjonstest

Etter installasjonen skal fullstendig funksjonsprøve med full last gjennomføres:

Prøvekjør løfteren opp og ned hele veien til respektive endeposisjoner. Kontroller at den går fritt uten hindringer og ulyder. Kontroller at ingen kabler og slanger kommer i klem og at vann- og avløpsslanger er fikserte i golv.

OBS!

Kjør løfteren opp til endeposisjon og kontroller at slangene er tilstrekkelig lange ovenfor fikseringspunktene.

EN Functional test

After installation a complete functional test with full load shall be made:

Run the lift down and up all the way to respectively end position. Check that it moves freely, without hindrance and jarring sounds. Check that no cables or hoses are jammed and that the water and sewer hoses are properly fixed to the floor.

Notice!

Raise the lift to the end position to check that the hoses are long enough.

DE Funktionstest

Nach der Montage ist ein Funktionstest unter voller Last vorzunehmen:

Fahren Sie den Lift bis zum Anschlag in die oberste und unterste Position. Der Lift muss dabei frei von Störgeräuschen laufen. Alle Kabel und Schläuche sind auf festen Sitz zu prüfen und dürfen nicht eingeklemmt werden.

Achtung!

Stellen Sie sicher das in der obersten Positionen alle Anschlüsse richtig fixiert sind und sich nichts lösen kann.

FR Test fonctionnel

Après l'installation d'un test fonctionnel complet à pleine charge doit être faite:

Exécutez le ascenseur vers le bas et tout le chemin à la fin respectivement poste. Assurez-vous qu'il se déplace librement, sans entrave et les sons discordants. Vérifiez qu'aucun câble ou tuyaux sont bloquées et que les tuyaux d'aqueduc et d'égout sont correctement fixés au sol.

Avis!

Soulever l'ascenseur à la position de fin de vérifier que les tuyaux sont assez longs.



GRANBERG



Granberg Interior AB
Box 6112 600 06, Norrköping
Tel: 011-19 77 50
E-mail: info@granberg.se
Internet: www.granberg.se



Granberg Deutschland GmbH
Eggeweg 91, 33617 Bielefeld
Tel: +49 521 1439983
E-mail: info@granberg.de
Internet: www.granberg.de

